

ELECTRIC TOOL PARTS LIST

■ ROTARY HAMMER
Model DH 38YE2

2010 • 01 • 13
(E1)

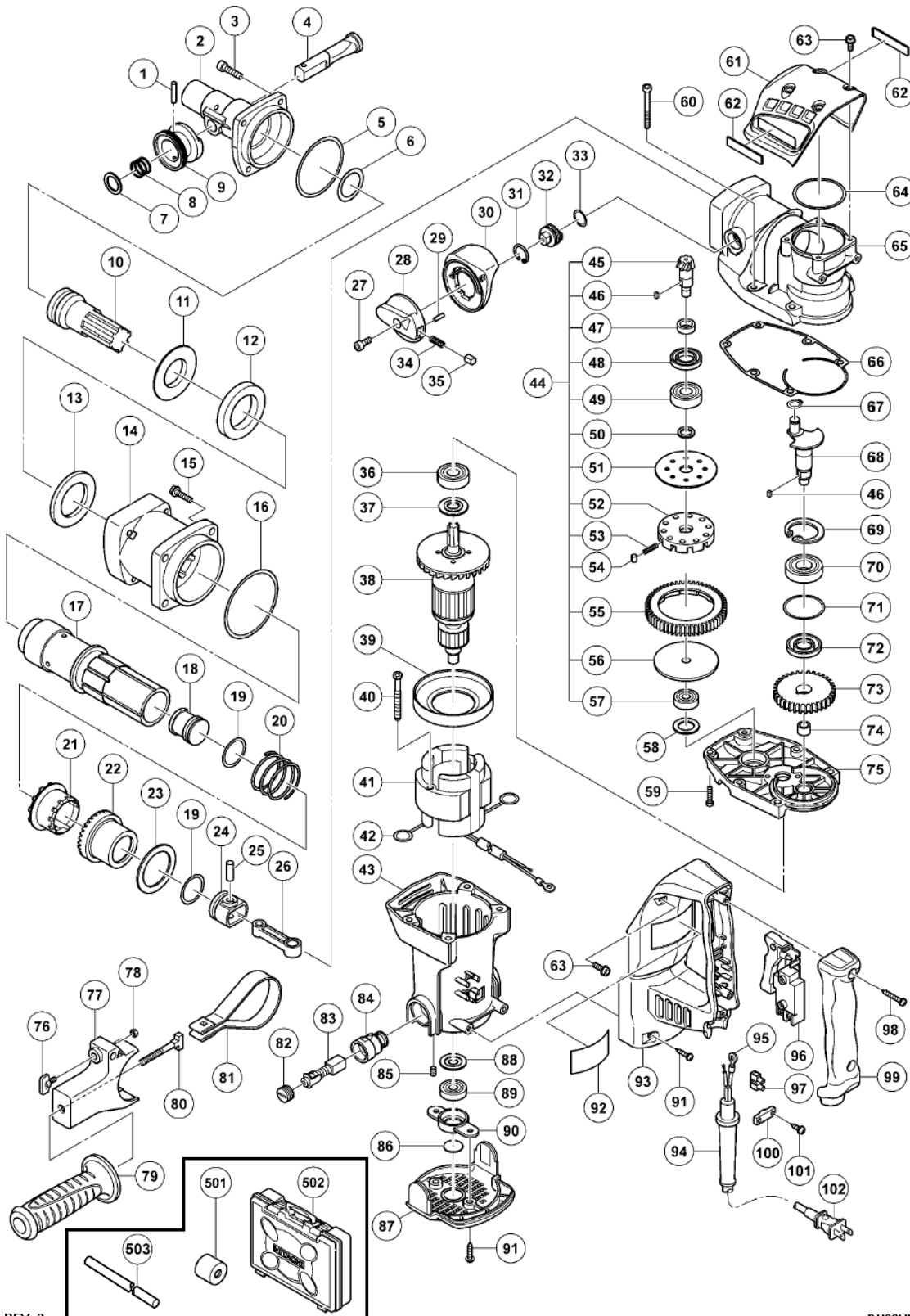

PARTS

DH38YE2

ITEM NO.	CODE NO.	DESCRIPTION	NO. USED	REMARKS
1	943364	NEEDLE ROLLER D4X20	1	
2	331868	FRONT COVER	1	
3	981942	SEAL LOCK HEX. SOCKET HD. BOLT M6X25	4	
4	985372	STOP LEVER (B)	1	
5	331244	O-RING	1	
6	981857	O-RING (C)	1	
7	331872	STOP WASHER	1	
8	331871	STOPPER SPRING	1	
9	331870	KNOB	1	
10	331863	SECOND HAMMER	1	
11	331865	DAMPER WASHER	1	
12	331864	DAMPER	1	
13	331866	DAMPER HOLDER	1	
14	331867	CYLINDER CASE	1	
15	991712	HEX. SOCKET HD. BOLT (W/FLANGE) M6X25	4	
16	956996	O-RING (1AS-60)	1	
17	331862	CYLINDER	1	
18	331874	STRIKER	1	
19	986104	O-RING	2	
20	331964	CLUTCH SPRING	1	
21	331528	CLUTCH	1	
22	331529	BEVEL GEAR	1	
23	331234	THRUST WASHER	1	
24	326369	PISTON	1	
25	331221	PISTON PIN	1	
26	321285	CONNECTING ROD	1	
27	983162	SEAL LOCK HEX. SOCKET HD. BOLT M4X12	1	
28	331545	CHANGE LEVER	1	
29	331548	PIN D2X10	1	
30	331873	LEVER HOLDER	1	
31	311229	RETAINING RING FOR D20 HOLE	1	
32	331543	LEVER SHAFT	1	
33	873095	O-RING (P-16)	1	
34	331546	LEVER SPRING	1	
35	321311	PUSHING BUTTON	1	
36	6201DD	BALL BEARING 6201DDCMPS2L	1	
37	325003	DUST WASHER (B)	1	
38	360875U	ARMATURE ASS'Y 120V	1	INCLUD.36.37.87.88
39	331252	FAN GUIDE	1	
40	953174	HEX. HD. TAPPING SCREW D5X55	2	
41	340753D	STATOR ASS'Y 120V	1	
42	930703	BRUSH TERMINAL	2	
43	331251	HOUSING ASS'Y	1	INCLUD.83.84
44	331210	SLIP CLUTCH ASS'Y	1	
45	331211	BEVEL PINION	1	
46	944109	FEATHER KEY 3X3X8	2	
47	331212	COLLAR	1	
48	313050	OIL SEAL (A)	1	
49	6002DD	BALL BEARING 6002DDCMPS2L	1	
50	331213	WASHER	1	
51	331214	WASHER (A)	1	
52	321281	GEAR HOLDER	1	
53	331218	SPRING (C)	10	
54	331217	NEEDLE	10	
55	331215	SECOND GEAR	1	
56	331219	SPACER	1	
57	629VVM	BALL BEARING 629VVC2PS2L	1	
58	331220	BEARING WASHER (C)	1	
59	992803	SEAL LOCK HEX. SOCKET HD. BOLT M6X20	2	
60	986940	SEAL LOCK HEX. SOCKET HD. BOLT M6X45	4	

